

Exercise 1

Technology Basics I

Mobile Business I (WS 2024/25)

Frédéric Tronnier

Chair of Mobile Business & Multilateral Security
Goethe University Frankfurt a. M.



- Exercise 1: Cell-based communication
- Exercise 2: Data Transmission Paradigms
- Exercise 3: Mobile Telecommunication Infrastructures
- Exercise 4: Classic Mobile Communication Services
- Exercise 5: Wireless LAN Components and Infrastructures

Exercise 1: Cell-based communication (from L02)

- a) What does **cell-based communication** mean and what are the implications,
- basic principle,
 - physical form,
 - dependencies?

Cell Based Communication (CBC)

What is a Cellular Network?

- Cellular networks are radio networks consisting of several **transmitters**.
- Each transmitter or base station, covers a certain area \Rightarrow **a cell**.
- Cell radius can vary from tens of meters to several kilometres.
- The shape of a cell is influenced by the environment (buildings, etc) and usually neither hexagonal nor a perfect circle, even though this is the usual way of drawing them.

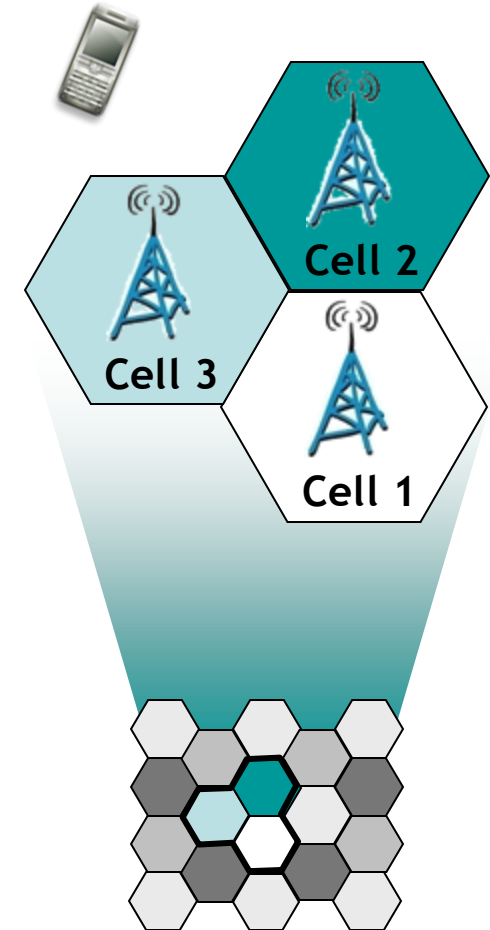

1a

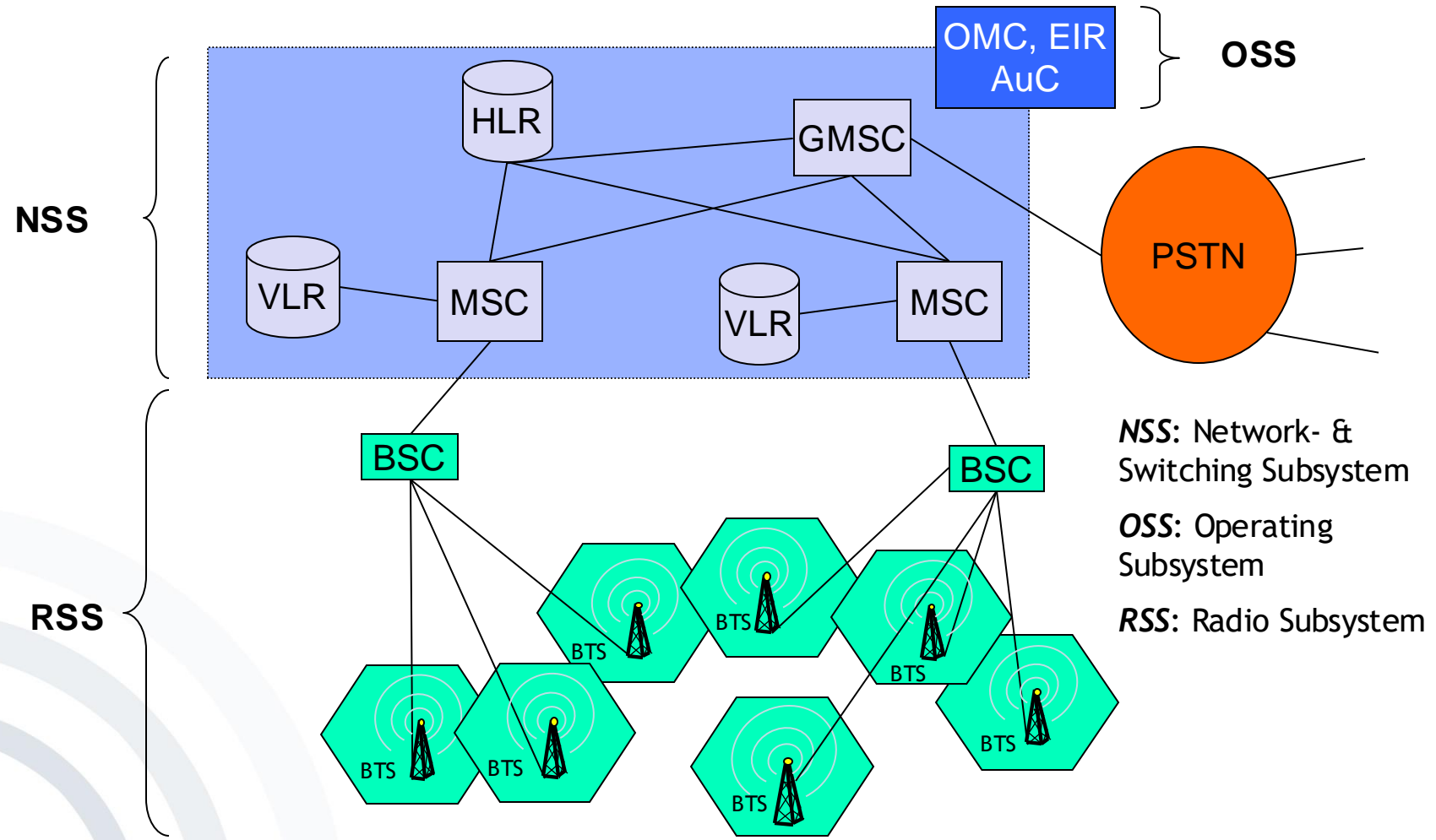

NSS: Network- & Switching Subsystem
OSS: Operating Subsystem
RSS: Radio Subsystem

- b) Write down the **advantages and drawbacks of cellular networks** compared to alternative solutions.

- Cellular networks offer a number of advantages compared to centralised radio systems:
 - **Higher capacity:** Cells offer the possibility to “reuse” the transmission frequencies assigned to mobile devices (e.g. by multiplexing). In order to do so, the networks need a thorough planning of the position of base stations and their frequencies.
 - ➔ More users can use the infrastructure
 - **Reduced transmission power:** Reduced power usage for the mobile device, due to the fact that only a limited amount of transmission power is needed in a small cell, compared to a far away base station.
 - ➔ Reduced power consumption for mobile devices

- Cellular networks offer a number of advantages compared to centralised radio systems:
 - **Robustness:** Cellular systems are decentralised with regard to their base stations. In the case that one antenna fails, only a small area gets affected.
 - ➔ Failure of one base station does not affect the complete infrastructure
 - **Better coverage:** Cells can be adapted to geographic conditions (mountains, buildings, etc.).
 - ➔ Better availability of the infrastructure

- However, there are also some drawbacks of cell based communication infrastructures:
 - **Required infrastructure:** A complex and costly infrastructure is required, in order to link all base stations. This includes switches, antennas, location registers, etc.
 - **Handover needed:** When changing from one cell to another, a handover mechanism is needed that allows a change of cells in real-time. These mechanisms are complex.
 - **Frequency planning:** The distribution of the frequencies being used for the base stations needs to be planned carefully, in order to minimise interferences, etc.

- c) In this context, explain “**Multiplexing**” and **why it is used** in communication systems.

- Fundamental mechanism in communication system Describes how several users can share a medium (e.g. mobile network) with minimum or no interference.
- **Goal:** Most efficient usage of a medium
- **Abstract example:** Traffic (users) using a highway with several lanes (medium) without accidents (interference)
- **Different Multiplexing techniques and methods exist:** space division, time division, frequency division multiplexing.

d) Explain the term “digital dividend”.

Frequency range of instruments of entertainment and communication electronics

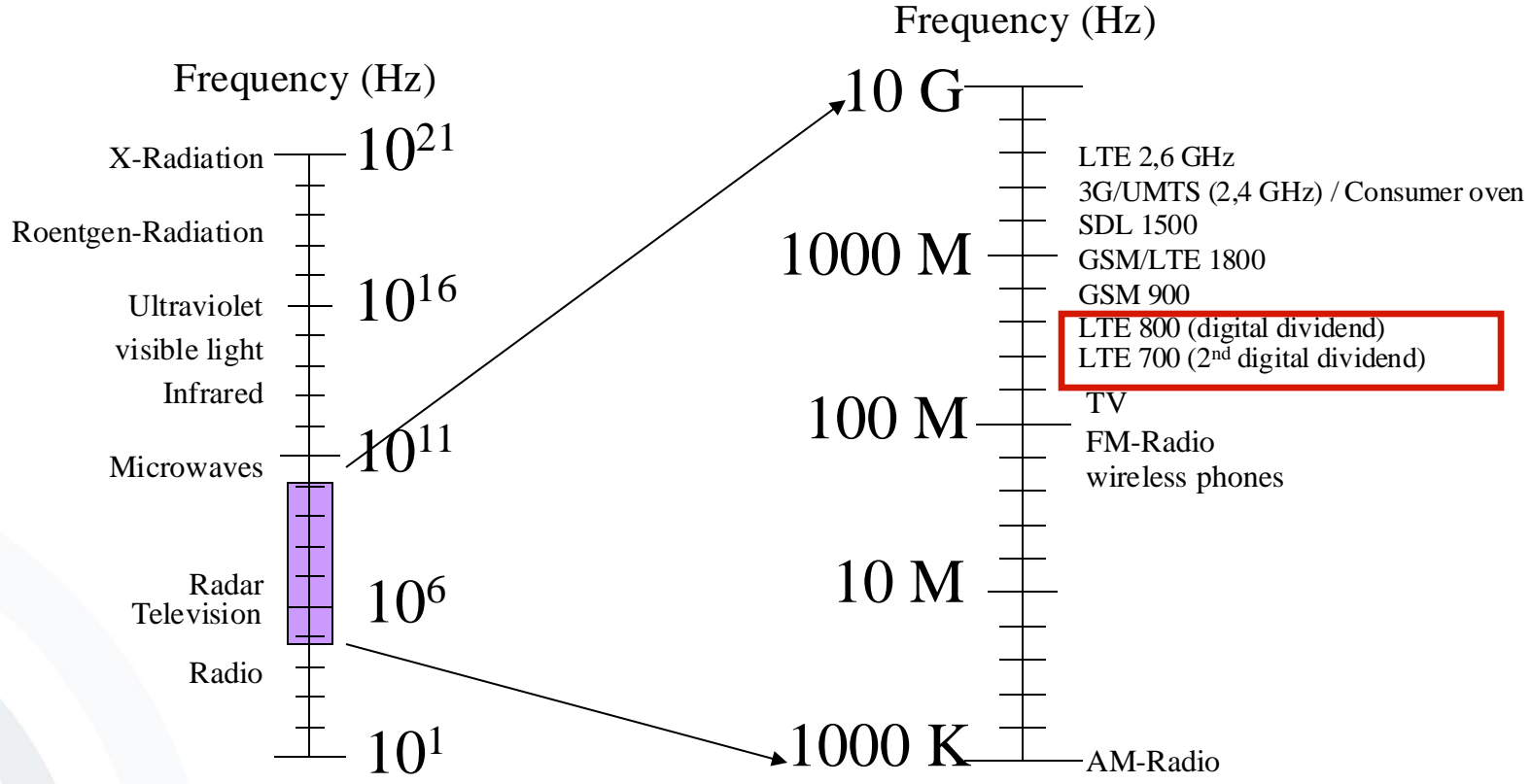

1d

- Exercise 1: Cell-based communication
- Exercise 2: Data Transmission
Paradigms for data transmission
- Exercise 3: Mobile Telecommunication
Infrastructures
- Exercise 4: Classic Mobile
Communication Services
- Exercise 5: Wireless LAN Components
and Infrastructures

- a) What are the **characteristics** (including advantages and disadvantages) of
- (i) **packet-oriented** and
 - (ii) **circuit-switched** mobile data services?

Mobile Data Services Packet-Oriented Networks

In packet-oriented networks, the communication is divided into several packets, which get addressed and transferred using a shared transmission medium (e.g. the Internet).

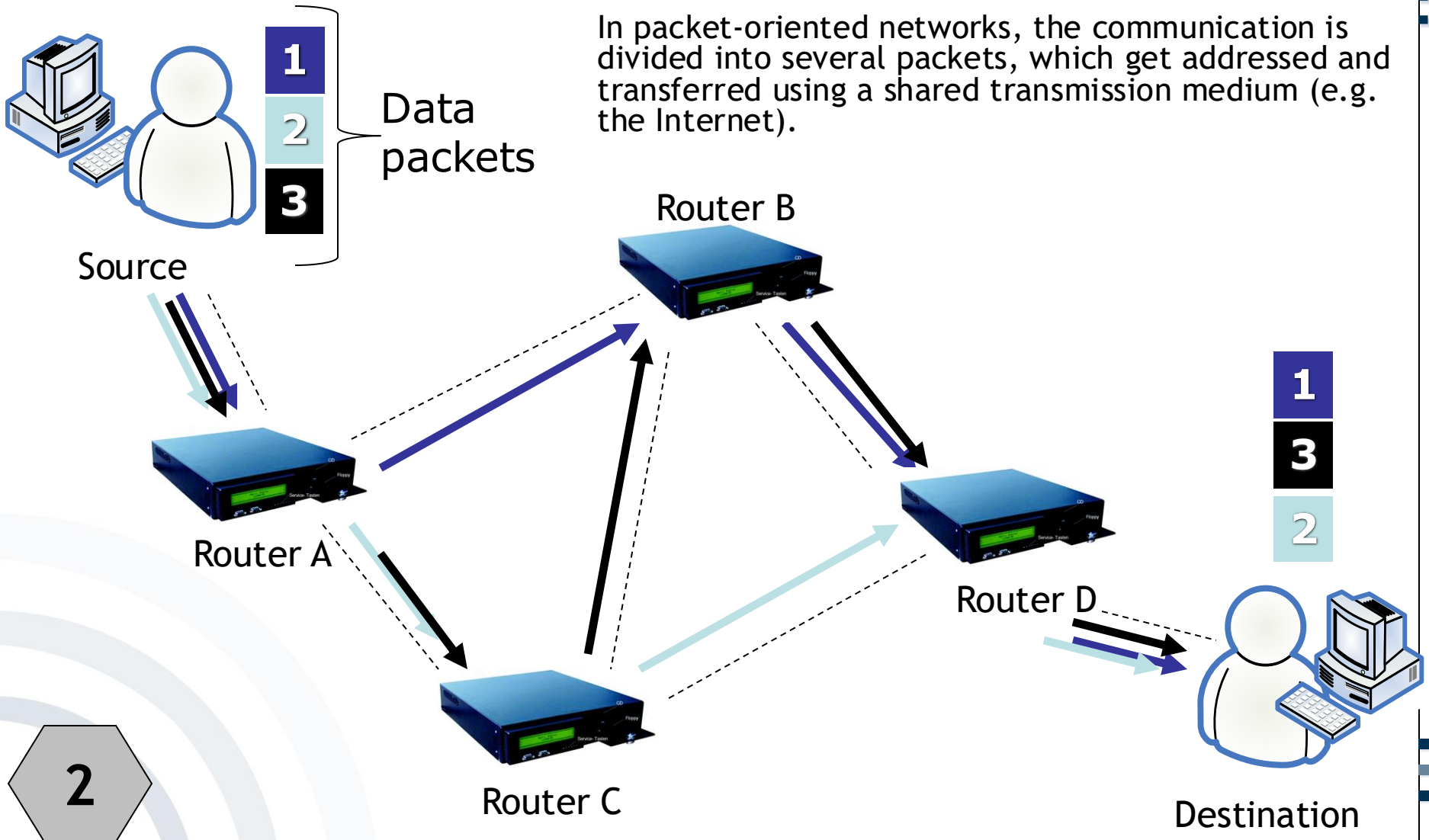

Mobile Data Services Circuit-Switched Networks

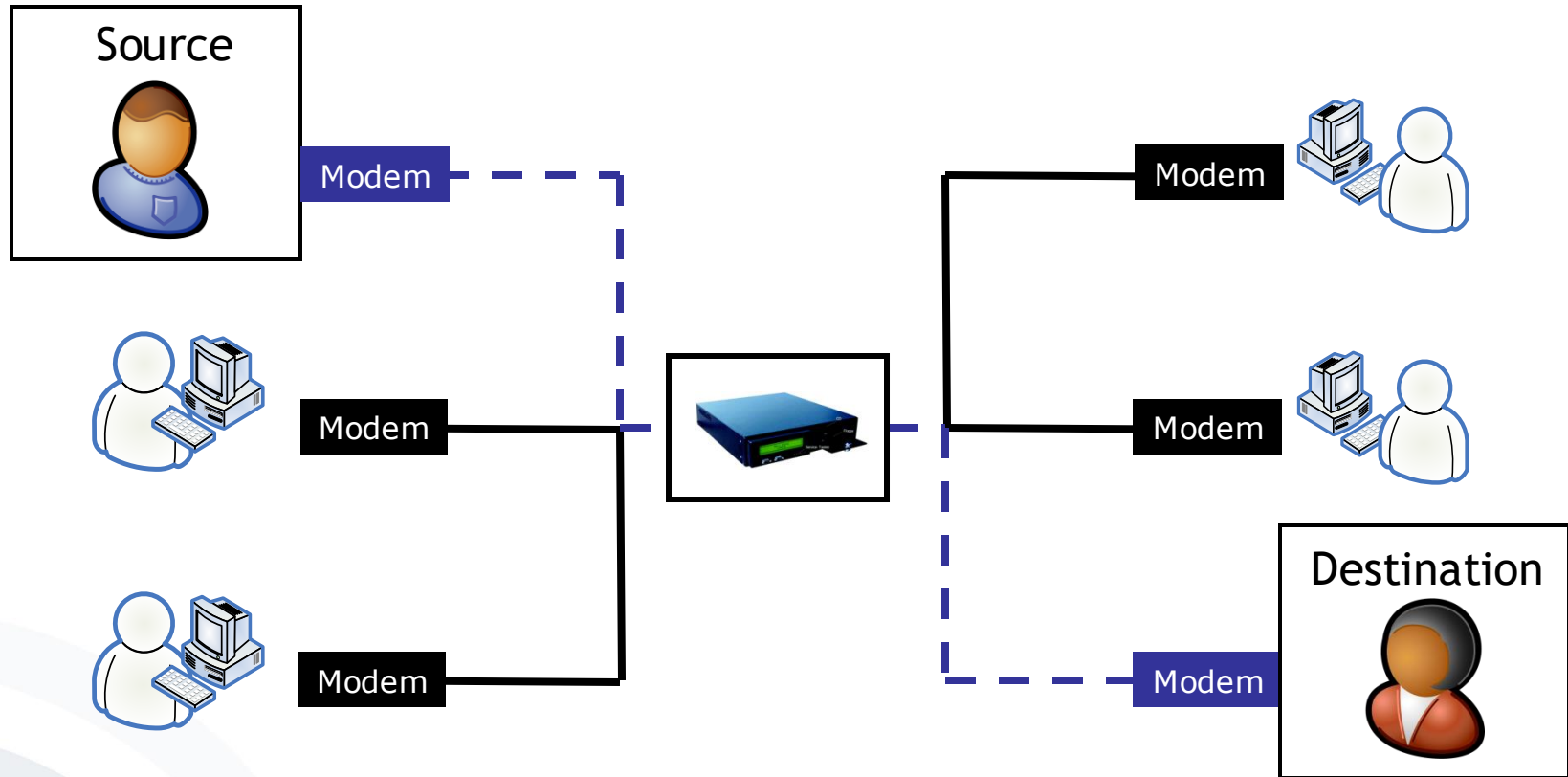

In circuit-switched networks, the communication line is used exclusively for the communicating parties (similar to the phone system, CSD and HSCSD).

There are two major paradigms for data transmission in communication networks:

- **Circuit-Switched:** In circuit-switched networks, the communication line is used exclusively for the communicating parties.
 - Connections are **exclusive** ➔ even if no data is transferred, the network resources are used.
 - In reality, the typical usage for voice connections is 30% of the network's capacity - for data transmission it is less than 10%.
 - The **duration of a connection** is used for billing purposes
 - Example: *Circuit Switched Data (CSD)* and *High-Speed Circuit Switched Data (HSCSD)* for Mobile Data Services
- **Packet-Oriented:** In packet-oriented networks, the communication is divided into several packets, which get addressed and transferred using a **shared** transmission medium.
 - The connection is kept all the time (always on). However, the network is only used when data is transmitted.
 - The capacity of the communication network is allocated dynamically.
 - For billing purposes, the **amount of transferred data** is used.
 - Example: GPRS for Mobile Data Services

- Advantages of (packet-oriented) GPRS over Circuit Switched Connections (CSD, HSCSD)

Economical network utilization

„Always-online“ allows offering new push services.

New billing methods can be realized (packet-oriented network).

- Disadvantages of (packet-oriented) GPRS compared to Circuit Switched Connections (CSD, HSCSD)

Existing GSM infrastructure must be upgraded implying high investments as well as new terminals

New push services require new security concepts, e.g. because of unintentional data reception (& payments for these data).

- Exercise 1: Cell-based communication
- Exercise 2: Data Transmission
Paradigms for data transmission
- Exercise 3: Mobile Telecommunication
Infrastructures
- Exercise 4: Classic Mobile
Communication Services
- Exercise 5: Wireless LAN Components
and Infrastructures

- a) Which are the three “security services” offered by GSM?

The GSM system offers different “security services“:

1. Access control and authentication:

- Authentication of the subscriber to the SIM by input of a PIN and to the GSM network by Challenge-Response-Procedure

2. Confidentiality:

- Data & voice transferred between mobile station and BTS are encrypted.

3. (Partial) Anonymity:

- No transfer of data which can identify the subscriber via radio, instead temporary identification
- (Temporary Mobile Subscriber ID, TMSI)

- b) Please outline and comment on the security model of the GSM infrastructure regarding subscriber authentication (challenge-response procedure for subscriber authentication)

- Challenge response protocol

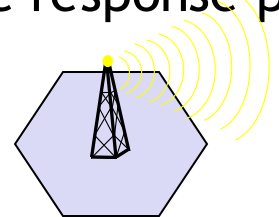

Mobile network



SIM

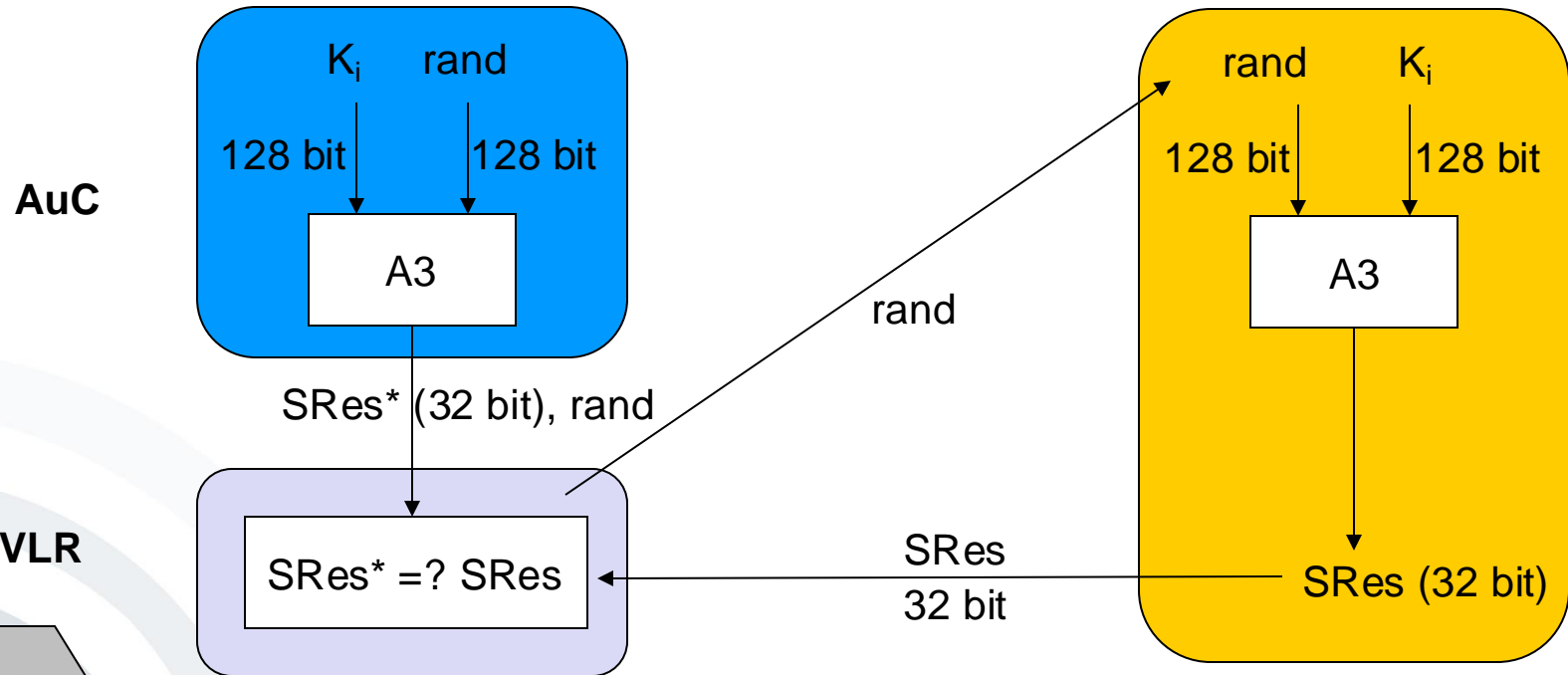

3b

K_i : individual subscriber authentication key
 A3: („secret“) authentication algorithm

$SRes$: signed response

- Challenge-Response-Procedure (Subscriber Authentication)
Authentication is based on the individual key K_i , the subscriber identification IMSI (International Mobile Subscriber Identity) and a secret algorithm A3.
- K_i and A3 are stored on the SIM and deposited in the AuC.
 1. AuC creates random number *rand*.
 2. AuC encrypts *rand* and K_i via A3 (->SRes*).
 3. AuC transfers *rand* and SRes* to VLR.
 4. VLR transfers exclusively *rand* to SIM.
 5. SIM computes with “own” K_i and A3 Signed Response SRes.
 6. The SRes computed by the SIM is transmitted to the VLR and is compared with SRes*.
 7. If SRes* and SRes are equal the subscriber is authenticated successfully.

- c) Name the weaknesses of the GSM security model and describe in particular the possible consequences resulting from these weaknesses.

- Solely authentication of the terminal/subscriber toward the **GSM network**. The network does not authenticate itself.
 - Assumption that the network is trustworthy per se
 - Security model was developed at a time with a provider monopoly
- Subscriber localization is almost exclusively controlled by the network.
 - Centralized movement tracking is possible
 - In order to avoid localization the subscriber must switch off the terminal.

- Security model based partly on secret encryption algorithms.
 - A3 and A8 were published without authorization.
 - Some operators use non-standardized algorithms.
- No encryption from terminal to terminal but solely over the air interface
 - Encryption deactivation by the network possible, without notification of the users
- Encryption comparatively “weak” because of key length (64 bit)
 - Sometimes the real key length is shorter.

d) What are the additional security features which were implemented in 3G (UMTS) networks compared to those of GSM?

- UMTS complements the security mechanisms known by GSM:
 - Enhanced participant authentication (EMSI)
 - Network authentication
 - Integrity protection of data traffic
 - Transferred security keys are also encrypted in the fixed network (e.g. HLR-VLR)
 - Increased key length
 - End-to-End encryption is possible.

- Exercise 1: Cell-based communication
- Exercise 2: Data Transmission
Paradigms for data transmission
- Exercise 3: Mobile Telecommunication
Infrastructures
- Exercise 4: Classic Mobile
Communication Services
- Exercise 5: Wireless LAN Components
and Infrastructures

- a) Which are the so-called Classic Mobile Communication Services?

- Voice / Fax Service
- Short Message Service (SMS)
- Mobile Data Services

b) Please describe each one of these services.

4b

▪ **Voice / Fax Service**

- Regular telephone service and emergency call
- Speech signals are digitally coded, using a bidirectional, symmetric, full-duplex point-to-point connection.
- Capable of sending and receiving “Group 3” fax transmissions

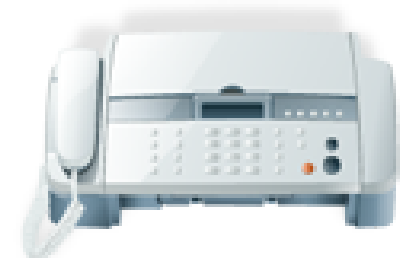

- Short Message Service (SMS)
 - Allows to send and receive short messages of up to 160 characters
 - **7Bit**: 160 characters (plain text)
 - **8Bit**: 140 characters (ASCII)
 - **16Bit**: 70 characters (Unicode)
 - Several SMS types exist:
 - *Point-to-point SMS* (single recipient)
 - *Point-to-multiple SMS* (several recipients)
 - *Cell broadcast SMS* (all users in a cell are recipients)
 - Combination with other value added services (e.g. automated mailbox notification)
 - Messages are sent to an SMS service centre (SMSC) and are processed in a *store-and-forward mode*, meaning that messages that cannot be relayed will be stored and sent again later.

- **Modem** (modulator-demodulator) in analogue mobile networks (300 - 2400 bit/s)
- **CSD** (Circuit Switched Data) in GSM networks (9.6 Kbit/s)
- **HSCSD** (High-Speed Circuit Switched Data) in GSM networks (57.6 Kbit/s max.)
- **GPRS** (General Packet Radio Service)
- **EDGE** (Enhanced Data Rates for Global Evolution)

4b

Evolution of Mobile Data

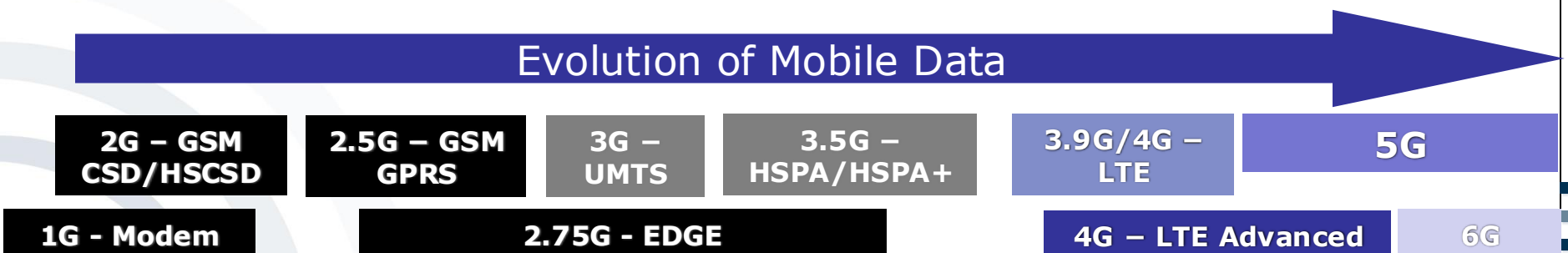

c) Mobile Data is one of the Classic Mobile Communication Services above.

When looking at GSM networks, which are the relevant Mobile Data Services?

- **Modem** (modulator-demodulator) in analogue mobile networks (300 - 2400 bit/s)
- **CSD** (Circuit Switched Data) in GSM networks (9.6 Kbit/s)
- **HSCSD** (High-Speed Circuit Switched Data) in GSM networks (57.6 Kbit/s max.)
- **GPRS** (General Packet Radio Service)
- **EDGE** (Enhanced Data Rates for Global Evolution)

4c

Evolution of Mobile Data

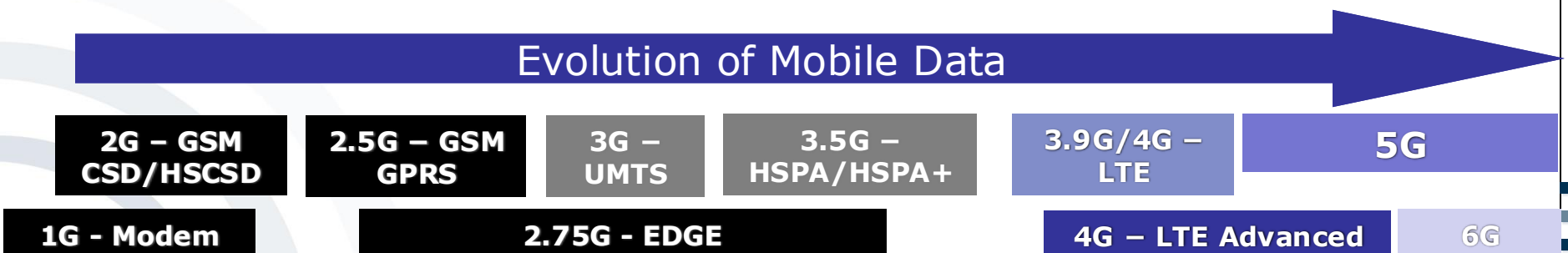

- Exercise 1: Cell-based communication
- Exercise 2: Data Transmission
Paradigms for data transmission
- Exercise 3: Mobile Telecommunication
Infrastructures
- Exercise 4: Classic Mobile
Communication Services
- Exercise 5: Wireless LAN Components
and Infrastructures

a) What are the components in a Wireless LAN?

- Components (802.11b)
 - Access Point (AP)
Sender and receiver station that allows the connecting of **multiple** receiving stations
 - Stations
End-systems that establish a wireless connection e.g. by using an Access Point (e.g. a notebook with built-in Wireless LAN)



b) Name two types of Wireless LAN networks.

Wireless LAN Infrastructure Types

Infrastructure Network

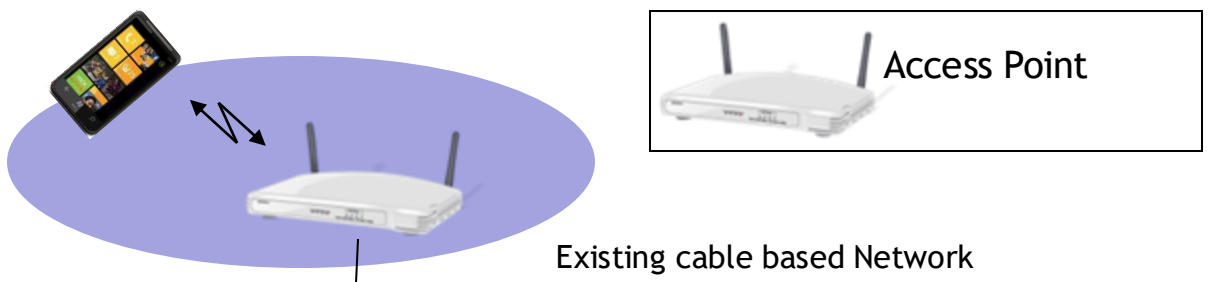

Ad hoc Networks



- c) In a wireless LAN environment, what is a so-called “Distribution system”? Also please explain Wireless LAN roaming within a distribution system.

Wireless LAN “Roaming”

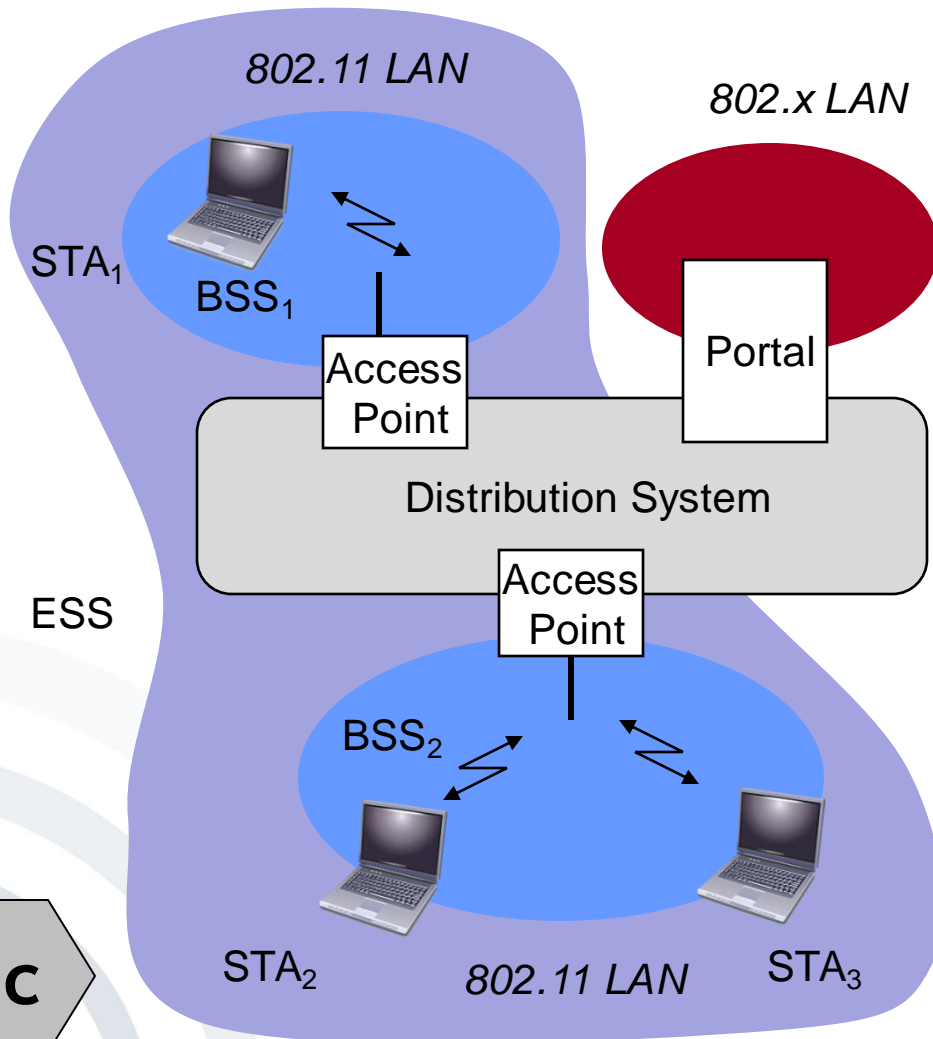

Station (STA)

- Computer with access to the wireless medium and radio connect to the AP

Basic Service Set (BSS)

- Group of stations, which use the same radio frequency

Access Point

- Station which is integrated into the radio as well as the fixed local area network (distribution system)

Portal

- Transfer into another network

Distribution systems

- Connection of different cells for building a larger network (ESS: Extended Service Set)

802.11 Tutorial

March 96

Roaming

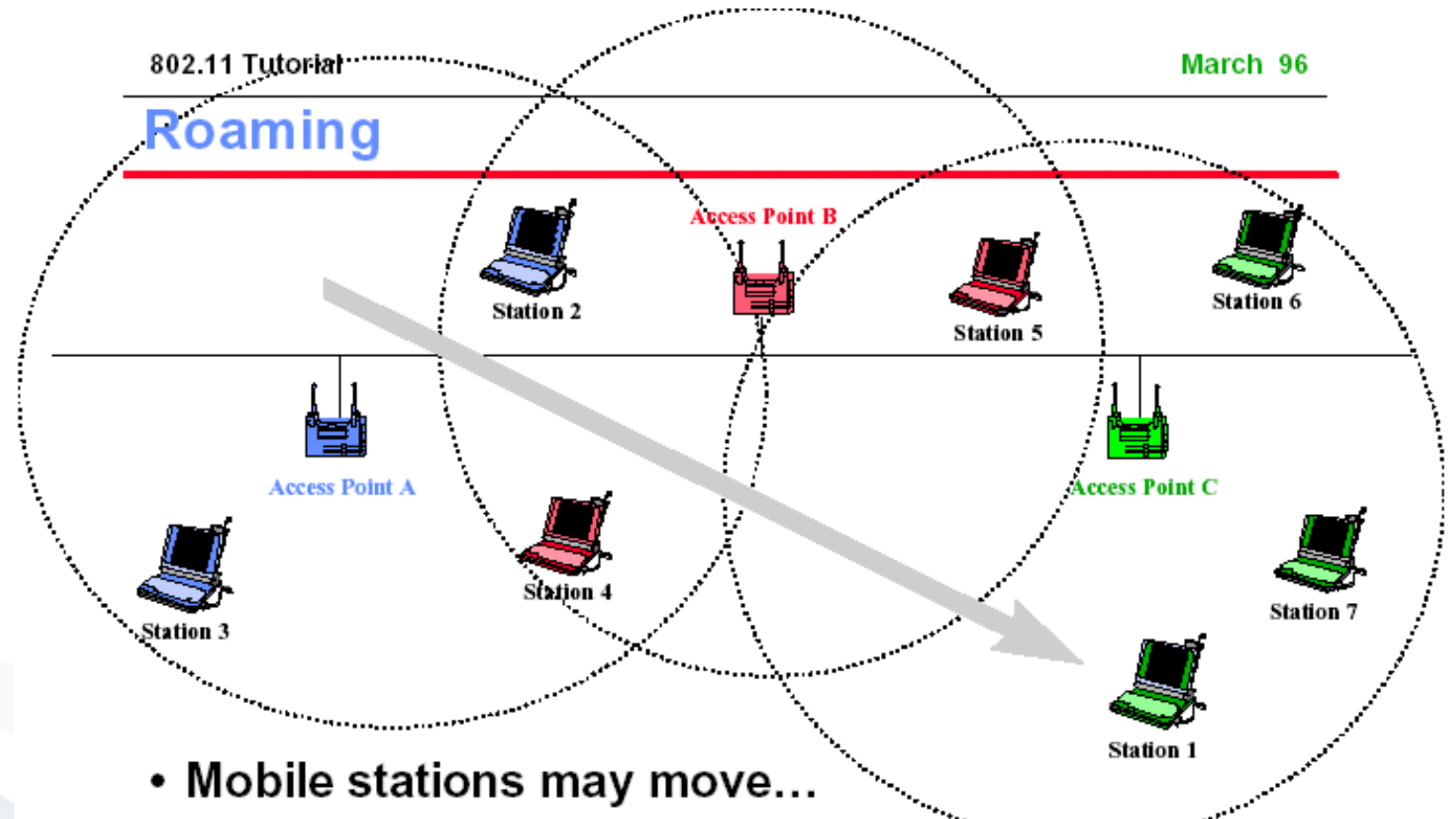

- Mobile stations may move...
 - beyond the coverage area of their Access Point
 - but within range of another Access Point
- Reassociation allows station to continue operation

5c

[IEEE1996]

- Approaches to perform roaming
 - By a combination of several Access Points a so-called distribution system is growing.
 - Every Access Point covers one radio cell.
 - Upon leaving a radio cell the station starts scanning for other existing Access Point and tries to connect.
 - Following the connection to a new Access Point the distribution system and the Access Point that was used before will be informed.

- d) There are numerous methods for Wireless LAN encryption. Which one of these offers reasonably secure encryption, using a pre-shared key?

- Most encryption methods are outdated and hence insecure:
 - Wired Equivalent Privacy (WEP) 64-bit
 - Wired Equivalent Privacy (WEP) 128-bit
- WEP 128-bit can be by-passed within minutes [Heise 2007].



- **Wi-Fi Protected Access (WPA)** was developed by the Wi-Fi Alliance.

[Wi-Fi 2010]

- There are three versions of **Wi-Fi Protected Access, WPA, WPA2 and WPA3:**



- **WPA** includes most of the 802.11i standard, but is **outdated and insecure** as it has various weaknesses:
 - Vulnerability to dictionary attacks when using a weak PSK
 - Other weaknesses inherited from earlier standards [ArsT 2008]
[ArsT 2008]
- **WPA2** includes **802.11i** to its full extent and also the Advanced Encryption Standard (AES).
- **WPA3** replaces pre-shared key (PSK) exchange with Simultaneous Authentication of Equals (SAE) exchange (IEEE 802.11s)

- This set of slides is based upon the following lectures:
 - ***Lecture 2:*** Basic Communication Paradigms and Mobile Telecommunications Infrastructures
 - ***Lecture 3:*** Wireless internet-oriented Infrastructures and Protocols
 - ***Lecture 4:*** Mobile Communication Services