

Business Informatics 2 (PWIN)
WS 2025/26

Management of ICT Projects

Prof. Dr. Kai Rannenber

Chair of Mobile Business & Multilateral Security
Johann Wolfgang Goethe University Frankfurt a. M.

- Introduction to ICT Projects
- Management of ICT Projects

Project characteristics according to DIN 69 901 “Project Management, terms”:

- Unique conditions
- Well defined goals and objectives
- Fixed start date and end date
- Limitations in terms of time, finance, staffing, etc.
- Differentiation from other projects
- Project-specific organisation

Particular Characteristics of ICT Projects

- Most of the time complex and innovative tasks
- Typical duration between 6 and 12 months
- Low degree of freedom (e.g. regarding costs and dates)
- Time and cost risk are very high and hard to measure for complex and innovative project types.
- Often many employees from different departments are involved:
→ Competition for resources within an enterprise
- Constantly changing technology
- Integration of interfaces to other Information Systems
- Consideration of existing legacy systems
- ...

- Development of customised Information Systems
- Selection, configuration, and introduction of standard software (e.g. ERP systems or security software)
- Planning and installation of ICT infrastructure
- ICT Projects for business process optimisation
- Outsourcing of ICT services or parts of the ICT infrastructure
- ...

Critical Success Factors for ICT Projects

- Clearly defined objectives and strategy
- Competent and motivated project members
- Commitment from company executives
- Efficient governance
- Realistic time and resource planning
- Integration of end users into the development process
- Risk management
- Efficient software development system and infrastructure
- ...

- Standish Group's CHAOS Summary 2009
 - 32% of all projects succeeded and were delivered on time, on budget, with the required features and functions.
(1995: 16,2%)
 - 44% of the projects were challenged in being late, over budget, and/or with less than the required features.
(1995: 52,7%)
 - 24% failed and were cancelled prior to completion or were delivered and never used.
(1995: 31,1%)

Failed ICT Projects in Practice

- Ariane 5
 - On June 4th, 1996 the first flight of the European Ariane 5 launcher crashed about 40 seconds after take off.
 - Reason: Specification and design error in the control software.
 - Media reports indicated that half a billion dollars were lost .
 - 10 years development time and 7 billion dollar development costs.

Failed ICT Projects in Practice

- **FoxMeyer ERP program (1993)**
 - 4th largest distributor of pharmaceuticals in the U.S. (worth 5 billion US Dollar)
 - **Project: Introduction of a SAP system and a warehouse automation system**
 - \$35 million project
 - Unrealistically aggressive time line (implementation in 18 months)
 - Result: Processing of 10,000 orders a night compared with 420,000 orders with the old mainframe
 - **1996: FoxMeyer filed for bankruptcy**
 - Sold for \$80 million

Failed ICT Projects in Practice

- FBI Virtual Case File
 - Project announcement in September 2000
 - Estimated time and budget: 3 years and \$120 million
 - April 2005 - FBI officially cancelled the project after spending \$170 million.

Computerpanne wirft Deut...

www.faz.net/aktuell/wirtschaft/unternehmen/computerpanne-wirft-deutsche-post-zurueck-13907222.html

Aktuelle Nachrichten ... SPIEGEL ONLINE - Nac... Meistbesucht Erste Schritte

FAZJOB.NET LEBENSWEGE SCHULE FAZ.NET F.A.Z.-E-PAPER F.A.S.-E-PAPER Anmelden Abo Mobil Newsletter Mehr

HERAUSGEGEBEN VON WERNER D'INKA, JÜRGEN KAUBE, BERTHOLD KOHLER, HOLGER STELTZNER

Was wird jetzt aus VW?

Frankfurter Allgemeine Wirtschaft Frankfurt 14°

Dienstag, 17. November 2015 VIDEO THEMEN BLOGS ARCHIV

POLITIK WIRTSCHAFT FINANZEN FEUILLETON SPORT GESELLSCHAFT STIL TECHNIK & MOTOR WISSEN REISE BERUF & CHANCE RHEIN-MAIN

Home > Wirtschaft > Unternehmen > Computerpanne wirft Deutsche Post zurück

DHL
Computerpanne wirft Deutsche Post zurück
 Nicht funktionierende Software kostet die Frachtparte DHL Millionen. Von Juli bis September ist der Gewinn um beinahe 90 Prozent abgesackt, der Aktienkurs fiel am Mittwoch um 4 Prozent. Der Rückschlag kratzt am Erfolgssimage von Vorstandschef Frank Appel.
 12.11.2015, von HELMUT BÜNDER

Meinungen (0) Merken Drucken
 Empfehlen (2) Permalink
<http://www.faz.net/-gqi-8a2vq>

Veröffentlicht: 12.11.2015, 08:50 Uhr

Kommentar

Kosten des Schreckens
 Von JOHANNES PENNEKAMP
 Auch die westliche Konsumgesellschaft wird vom islamistisch motivierten Terror attackiert. Aber die wirtschaftlichen Folgen dürften überschaubar bleiben, falls nicht in kurzem Abstand weitere Anschläge folgen. **Mehr** ★ 2

Die Börse 17.11.2015 03:55 Uhr

Name	Kurs	Änderung
Dax	10.713,23	+0,05 %

10.000,00
6.000,00
2010 2013 2015

DHL-Zentrum in Hongkong: Jedes Rad muss bei der Pakettlieferung ins andere greifen.
© BLOOMBERG

Es sind gigantische Mengen, die die Deutsche Post DHL jedes Jahr rund um den Globus befördert. Ihre Transportflugzeuge und Containerschiffe verbinden die Kontinente, sorgen für Nachschub in Fabriken und gefüllte Regale im Einzelhandel. Rund 220 Länder steuert die Frachtparte der Post an, in Europa ist eine riesige Flotte von Lastwagen und Eisenbahnwaggons für DHL unterwegs. Da muss ein Rädchen perfekt in das andere greifen, damit die Ware...

SZ Arbeitsagentur stoppt 60 x

www.sueddeutsche.de/digital/it-panne-sechs-jahre-millionen-euro-aber-keine-software-fuer-die-arbeitsagentur-1.3382464

München 23°

Süddeutsche Zeitung
SZ.de Zeitung Magazin

Politik Wirtschaft Panorama Sport München Bayern Kultur Wissen Digital Chancen Reise Auto Stil mehr...

Home > Digital > Arbeitsagentur stoppt 60-Millionen-Euro-IT-Projekt

16. Februar 2017, 15:38 Uhr IT-Panne

Sechs Jahre, 60 Millionen Euro - aber keine Software für die Arbeitsagentur



Mehr als sechs Jahre entwickelt, 60 Millionen Euro investiert - jetzt stoppt die Arbeitsagentur das IT-Projekt "Robaso". (Foto: dpa)

- Nach mehr als sechs Jahren Entwicklungszeit hat die Bundesagentur für Arbeit das IT-Projekt "Robaso" gestoppt.
- Die Software kostete bislang etwa 60 Millionen Euro.
- Der Bundesrechnungshof wird den Fall prüfen.

ANZEIGE

Hewlett Packard Enterprise
Präsentiert von HPE und Intel®
Fitness-Programm für die

Source: Strathmann (2017)

Luca im Voraus bezahlt

Als "besonders gravierend" wertet der BdSt die Tatsache, dass das Land bei der Luca-App die Jahreslizenzen inklusive der Kosten für Rechenzentrenkapazitäten im Voraus bezahlt und nicht auf nutzerabhängige Preismodelle gesetzt habe. Für den Anbieter dürfte der finanzielle Vorteil daher "umso höher sein, je weniger die App genutzt wird". Die Beschaffung sehe so "wenig strukturiert und kaum nachhaltig aus". Dazu komme, dass eine ganze Reihe weiterer Bundesländer ähnliche Lizenzen aus öffentlichen Mitteln in Höhe von insgesamt rund 21 Millionen Euro erworben haben sollen.

Zum Start der Corona-Impfkampagne habe in Deutschland kein System zur Verfügung gestanden, um die Impfungen "sofort elektronisch zu erfassen und später unkompliziert in das europäische Impfbzertifikat zu übertragen", beklagen die Prüfer auch unnötig teure digitale Covid-Impfnachweise. Anfangs erhielten Ärzte und Apotheker für das nachträgliche Ausstellungen der entsprechenden QR-Codes bis zu 18 Euro pro Stück, später bis zu sechs Euro. Wie hoch die Gesamtkosten ausgefallen sind, habe das Bundesgesundheitsministerium noch nicht sagen können.



Bild: Sebastian Duda/Shutterstock.com

- Ransomware is a malware software which encrypts the victim's files and requests a payment to decrypt the files.
- WannaCry(pt) is a ransomware software which makes use of vulnerabilities of outdated Windows XP systems.
- Microsoft still provides Windows XP updates but not for free. Therefore, it is an economic cost/benefit decision to update or not to update a system.
- In case of the U.K. National Health Service it was a political decision taken at the highest level of the government not to spend money to keep receiving security updates.
- Security incidents can often be explained by an economic/political perspective on information security.

Consequences of Bad Project Management

- Budget overruns
- Exceeded project durations
- Technical inadequacies reducing the performance of an Information System
- Planned benefit of an Information System not achieved

Why Do Projects Fail?

- Bad project planning
- Vague objectives
- Inadequate/incomplete requirements
- Inadequate management in areas such as risk, scope or quality
- Inadequate methodologies
- Lack of resources
- Unrealistic expectations

Influencing Factors on the Success of Projects

- Project leader's methodological competence
- Social competence of involved personnel
- Project leader
- Team
- Customer

- The magic triangle of project management

The Magic Triangle of Project Management

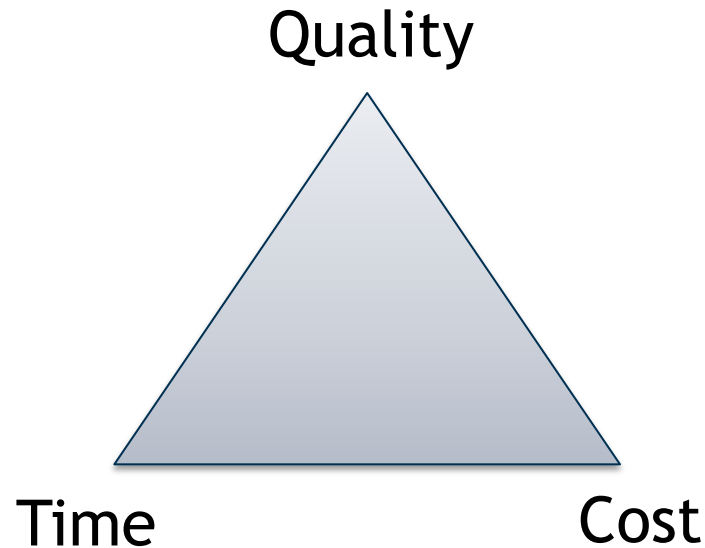

Requirement Change	Consequences	
Shorter time	Higher costs	Reduced quality or scope
Reduced costs	More time	Reduced quality or scope
Higher quality	More time	Higher costs

Identified factors are related to

ICT project management



**ICT project management is essential
for the success of ICT projects**

- Introduction to ICT Projects
- Management of ICT Projects

- **Project management** is the complete set of tasks, techniques, tools applied during project execution.

Source: DIN 69901-5:2009-01

- **Project management** is the application of knowledge, skills, tools, and techniques for project activities to meet project requirements.
Project management is accomplished through the application and integration of the project management processes of initiating, planning, executing, monitoring, controlling and closing.

Source: PMBOOK (2008)

Management of ICT Projects

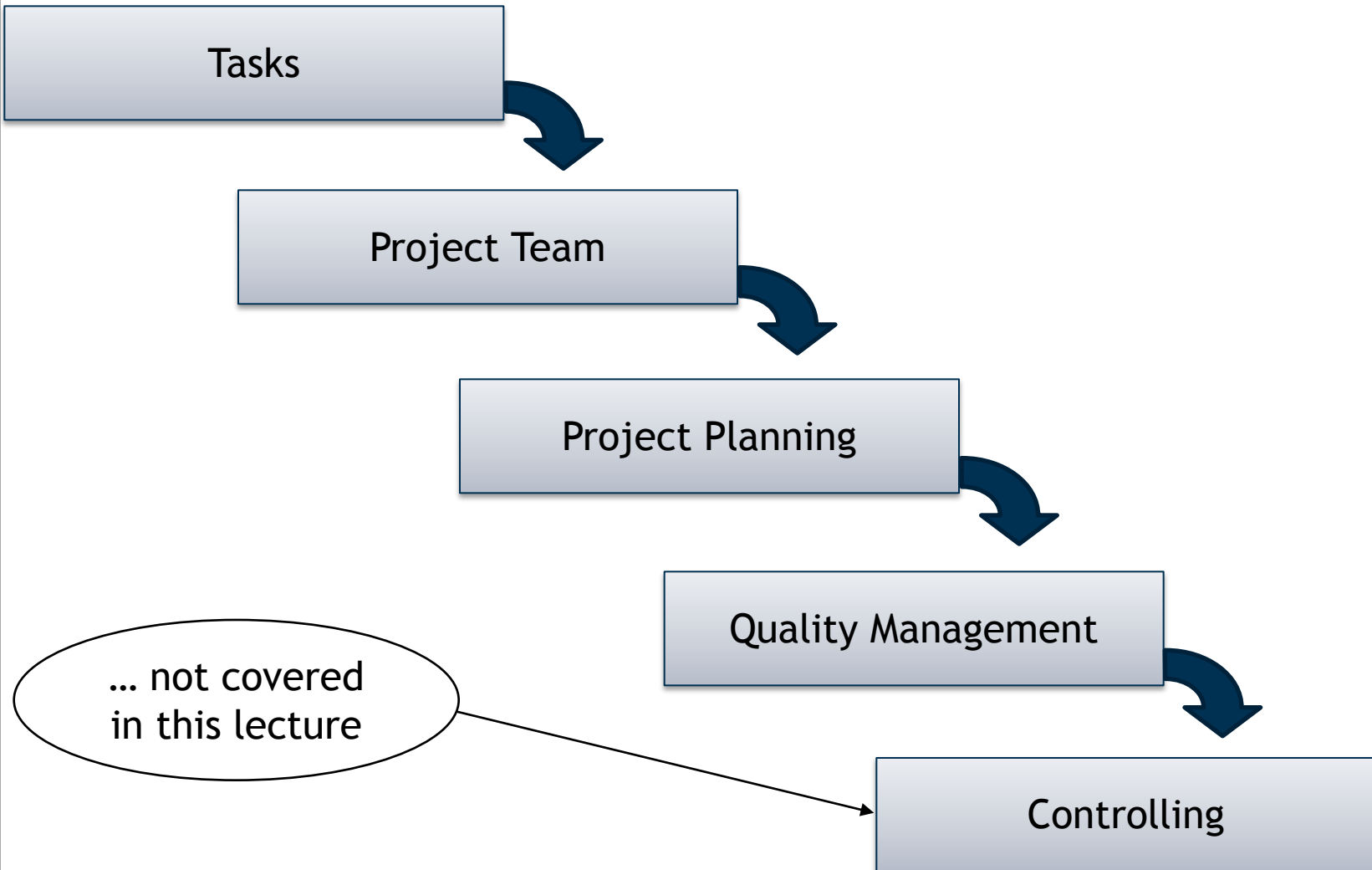

Project Management Tasks

- Initiation of the decision to carry out the project
- Organisation of the project
- Planning of performance, dates, resources, costs, finances and budget
- Allocation of tasks, competencies and responsibilities
- Teambuilding
- Human Resource Management
- Leadership
- External coordination and communication
- Documentation and reporting
- Controlling of the project's activities: meeting deadlines, cost control, budget control
- Project closing

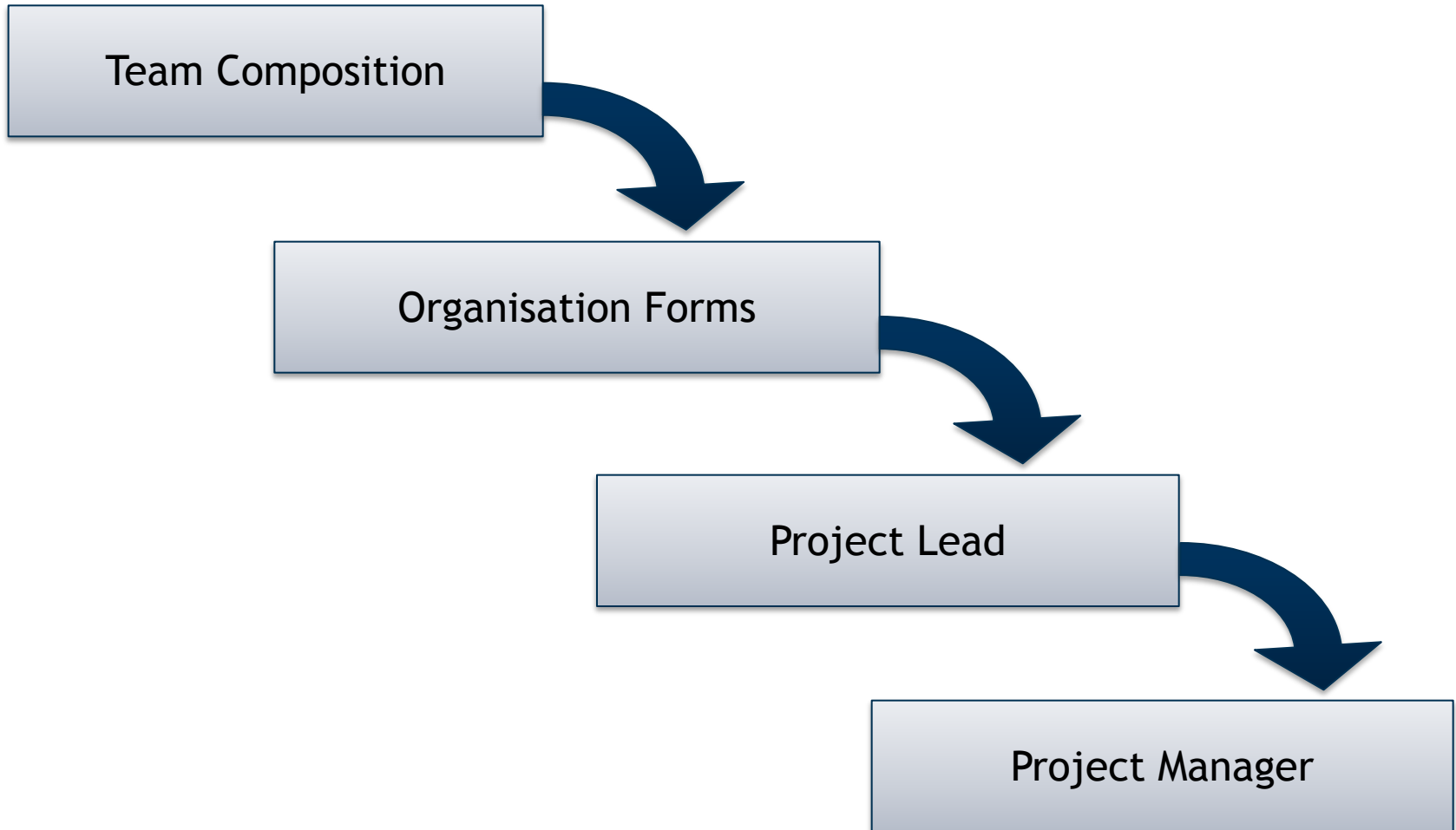

Team Composition

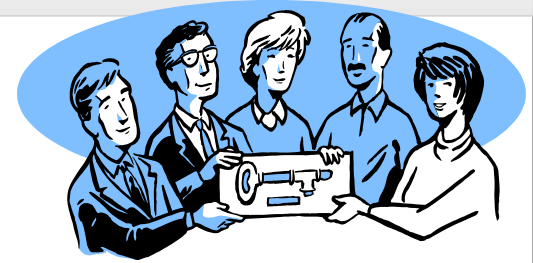

- Client
- Personnel from involved departments
- Consultants, system analyst, system developer
- Project manager
- Project controller
- External specialists
- ...

Organisation Types of the Project Team

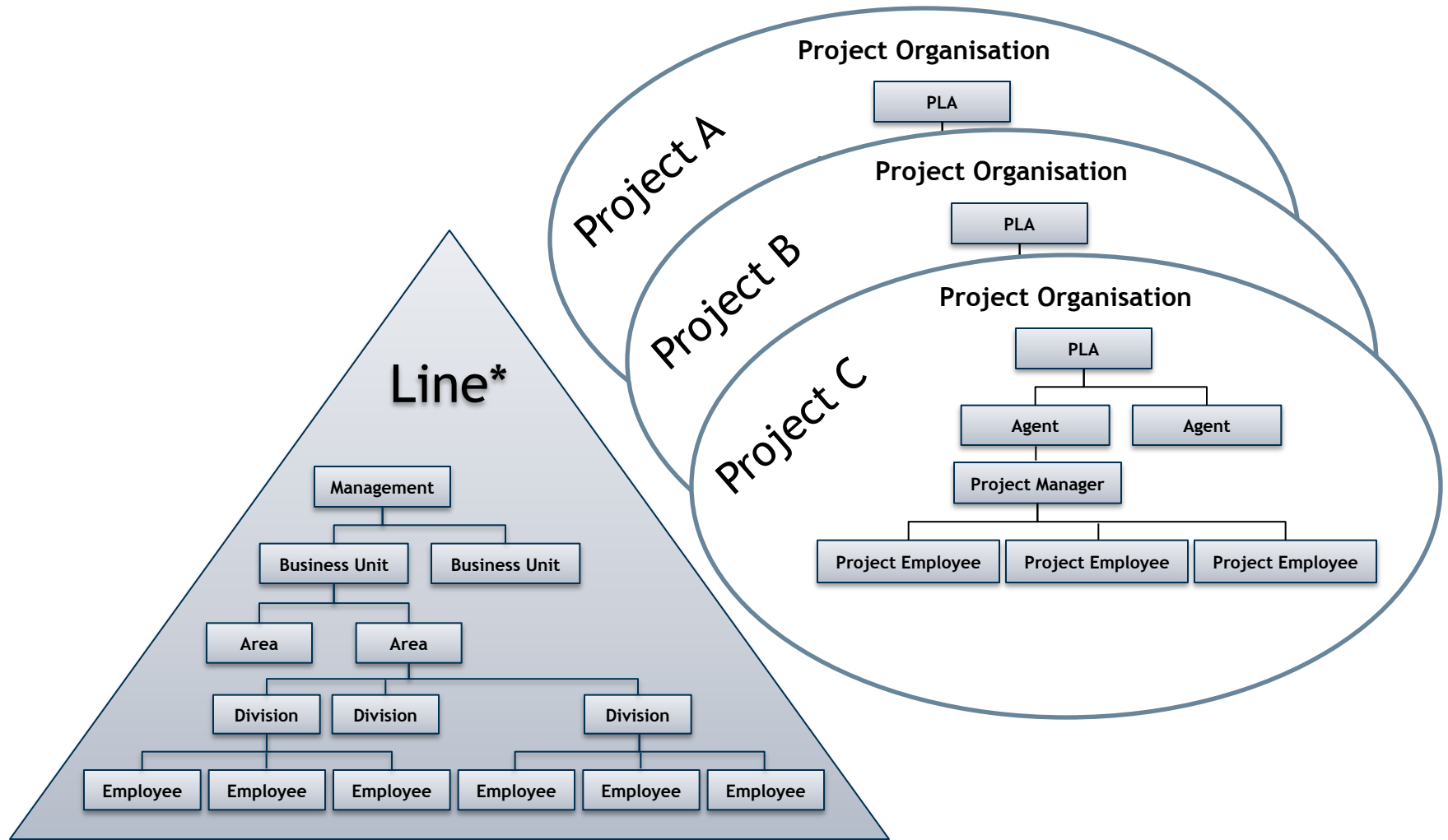

Organisation Types of the Project Team

Depending on the type of the project, different types of organisation for the project can be chosen:

- **Matrix organisation**
 - Team members are only delegated to the project team for the time they are needed in the project.
- **Pure project organisation**
 - Team members are transferred to the project team for the whole duration of the project and return to their department at the end of the project.
- **Project laboratory organisation**
 - Mixture of the above organisation forms: Team members of the ICT department are permanently assigned to the project, whereas team members from other departments join the project only on a temporary basis.

Possible project lead constellations

- Project lead on the user's side
- Project lead on the developer's side
- Divided project lead between user / developer
- Project lead by an external consultant

- Basic competence
 - Management
 - Leadership
 - Analytical thinking

- Social competence
 - Social awareness
 - Communication
 - Motivation

- Organisational competence
 - Self organisation
 - Reporting
 - Documentation

- Methodological competence
 - Schedule and process management
 - Management of resources
 - Cost controlling
 - Controlling the project's activities
 - Project coordination (coordinating the activities of the project team)
 - Internal and external communication
 - Reporting
 - Risk management

Main Functions of a Project Manager

- Defines scope of project
- Identifies relevant stakeholders & leaders (decision makers: clients, parent organisations, project team, the public)
- Evaluates project requirements
- Develops detailed task list (tasks breakdown, project structures)
- Develops initial project management flow chart
- Estimates time requirements
- Generates cost estimation and budget overview
- Identifies and allocates required resources
- Evaluates risks

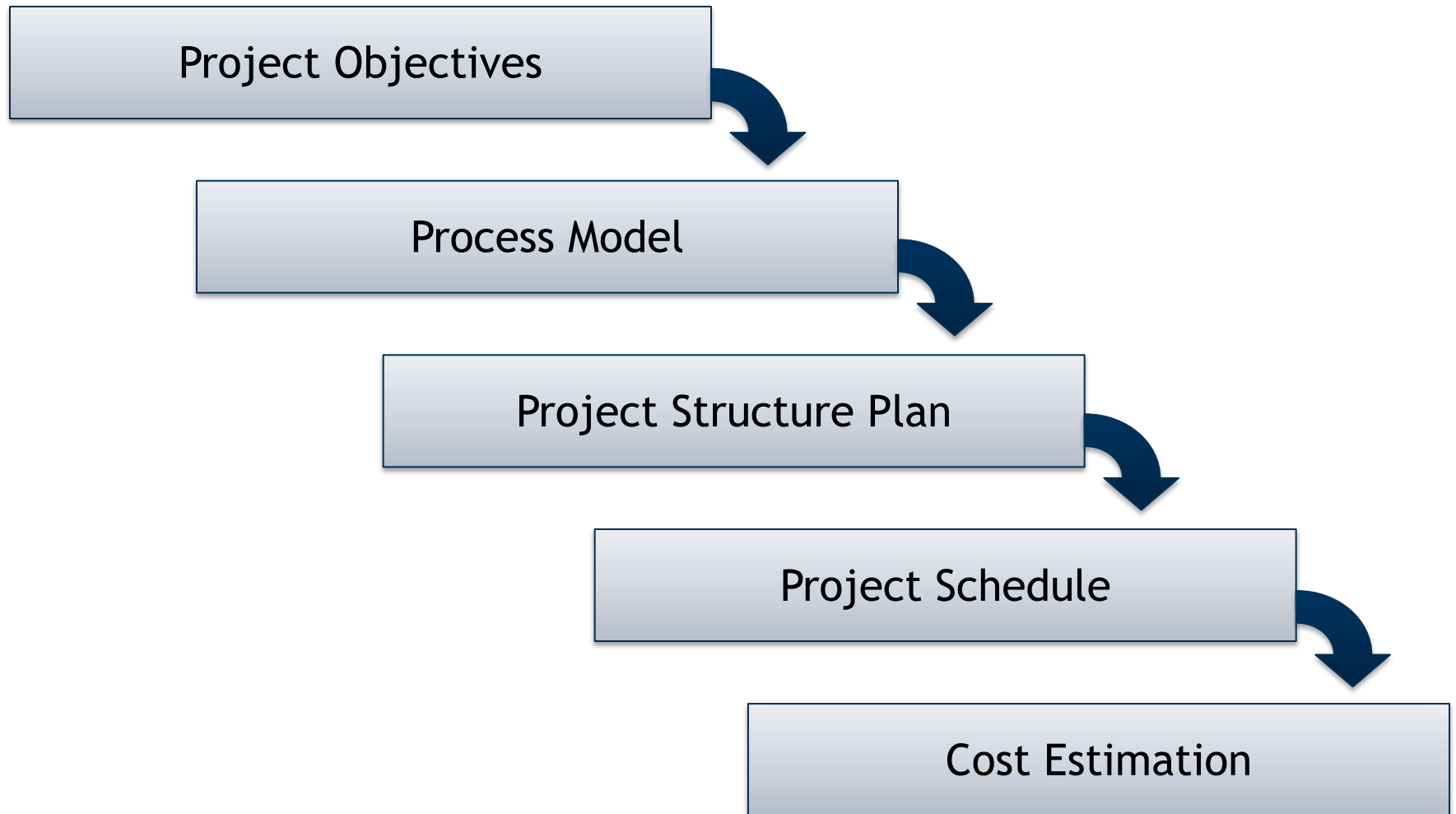

SMART Project Objectives

- **S**pecific:
 - Desired objectives should specify what should be achieved and include some quantitative targeted values for the end product.
- **M**easurable:
 - You should be able to measure whether the objectives have been met or not.
- **A**ttainable:
 - The desired objective must be one that is actually feasible to achieve within the given time and cost parameters.
- **R**elevant:
 - The desired objective should relate directly to the organisation's business needs and stated mission.
- **T**ime-bound:
 - The boundaries for completion date of the desired objective should be either a specific date or time.

General Process Model (example)

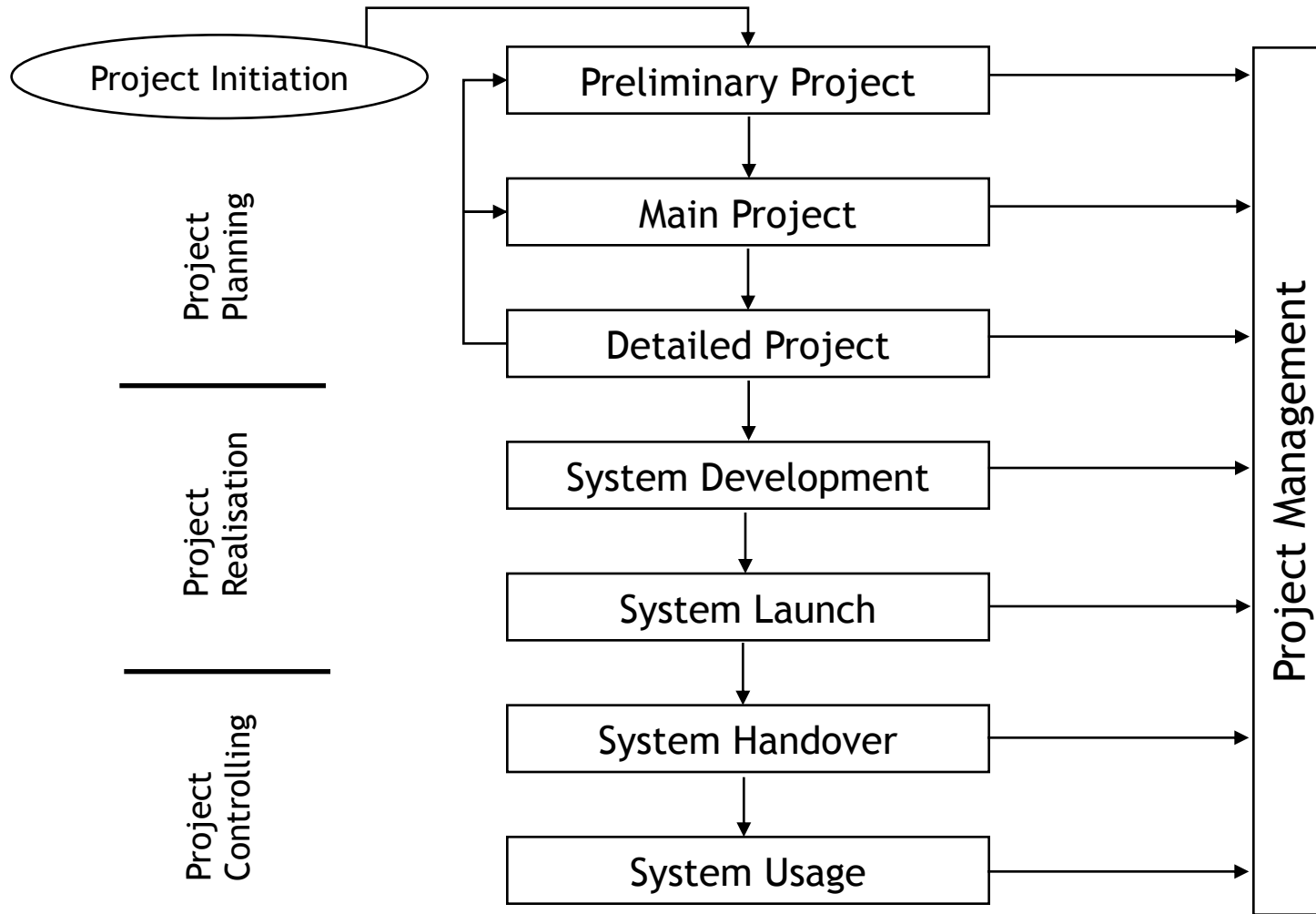

Source: Kargl (2000)

- The *project schedule* is a calendar that links the **tasks** to be accomplished with the **resources** allocated to the tasks.
- Before a project schedule can be created, a work breakdown structure (WBS), an effort estimate for each task, and a resource list with availability for each resource has to be available to the project manager.
- How to create a project schedule:
 - Identify the temporal and logic sequence of the tasks.
 - Check which packages can be processed in parallel or successive manner.
 - Schedule the single work packages.
- Techniques for creating project schedules:
 - Gantt charts
 - Network analysis (for more complex projects)

Example: Gantt Chart (1/2)

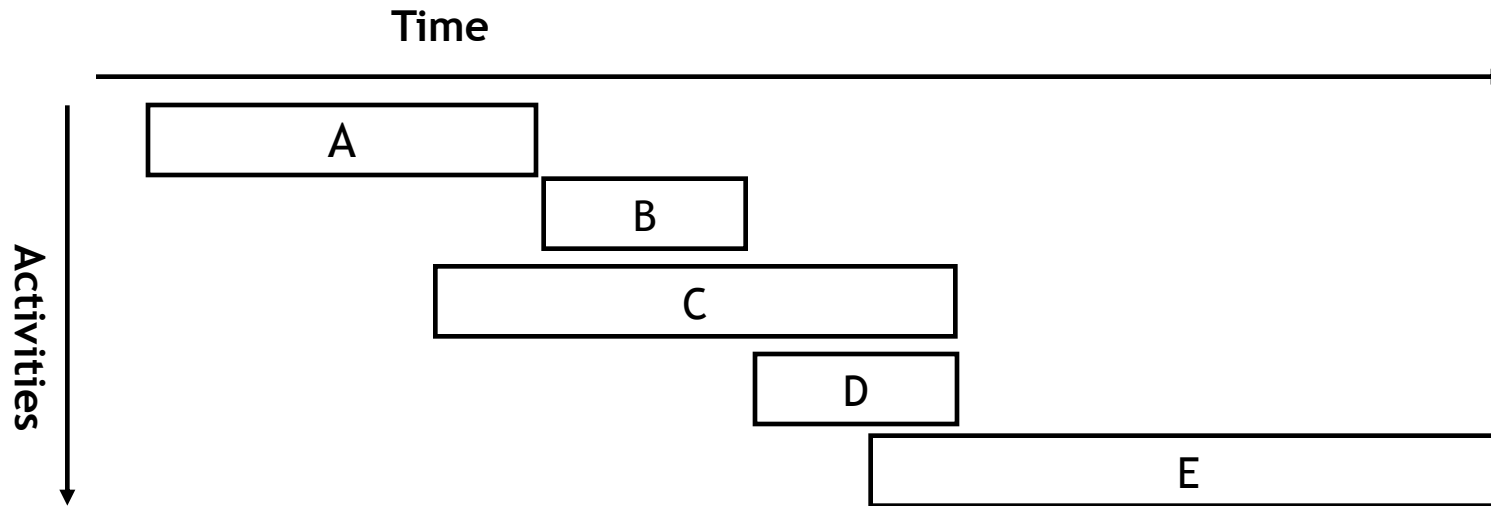

ID	Task Name	Duration	Predecessors	May '05	Jun '05	Jul '05	Aug '05	Sep '05	Oct '05	Nov '05	Dec '05				
1	Software Project	172.5 days		[Gantt bar for task 1]											
2	Requirements	7 wks		[Gantt bar for task 2]											
3	Design	5 wks	2	[Gantt bar for task 3]											
4	Programming	60 days	3	[Gantt bar for task 4]											
5	Unit Tests for Feature A	3 wks	3	[Gantt bar for task 5]											
6	Program Feature A	7 wks	5	[Gantt bar for task 6]											
7	Unit Tests for Feature B	4 wks	3	[Gantt bar for task 7]											
8	Program Feature B	8 wks	7	[Gantt bar for task 8]											
9	Feature-Complete Build	0 days	6,8	[Gantt bar for task 9]											
10	Test Preparation	40 days		[Gantt bar for task 10]											
11	Build Test Plans	6 wks	2,3,FF	[Gantt bar for task 11]											
12	Review, Correct Test Plans	2 wks	11	[Gantt bar for task 12]											
13	Test Execution	52.5 days	12	[Gantt bar for task 13]											
14	Execute Test Plan A	3 wks	9	[Gantt bar for task 14]											
15	Execute Test Plan B	1.5 wks	14,SS	[Gantt bar for task 15]											
16	Fix Defects	1 wk	14,15	[Gantt bar for task 16]											
17	Regress Test Plan A	6.5 wks	16	[Gantt bar for task 17]											
18	Regress Test Plan B	3 wks	17,SS	[Gantt bar for task 18]											
19	Deliver Beta Build	0 days	17,18	[Gantt bar for task 19]											

Example: Gantt Chart in Software Development (2/2)

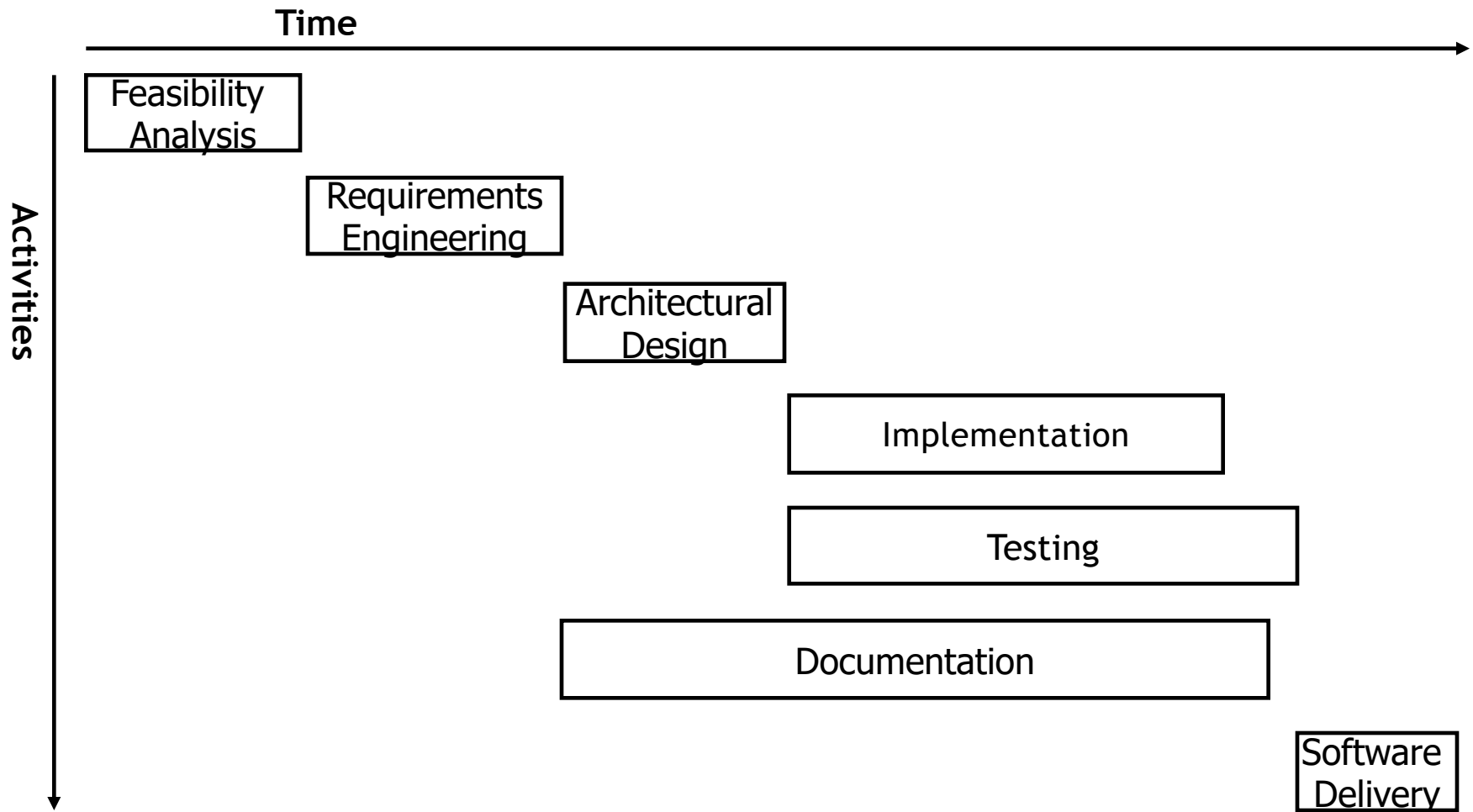

Example: Network Plan (1/2)

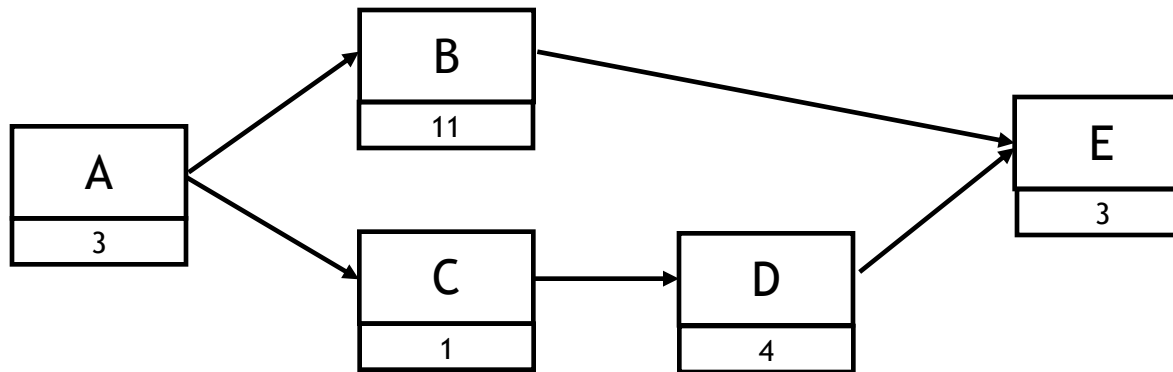

Order relation



Example: Network Plan in Software Development (2/2)

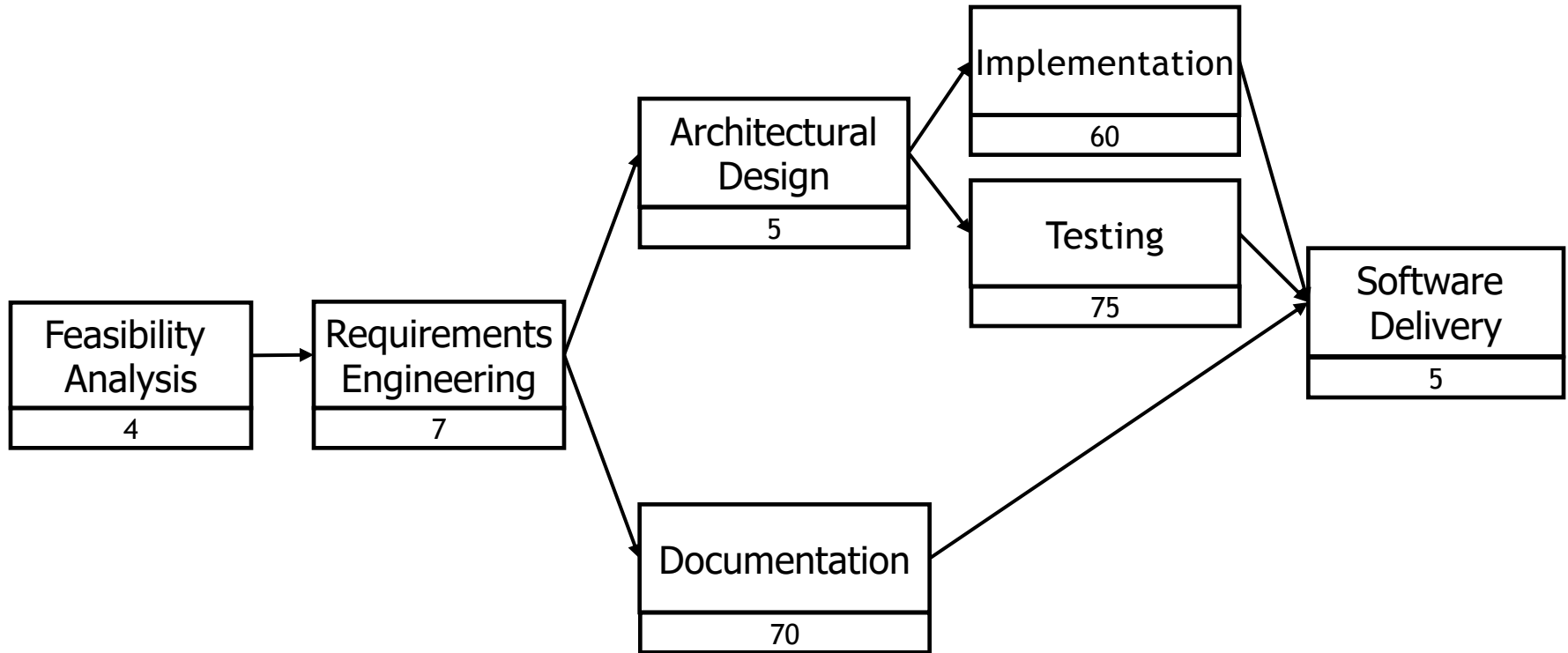

Project Structure Plan

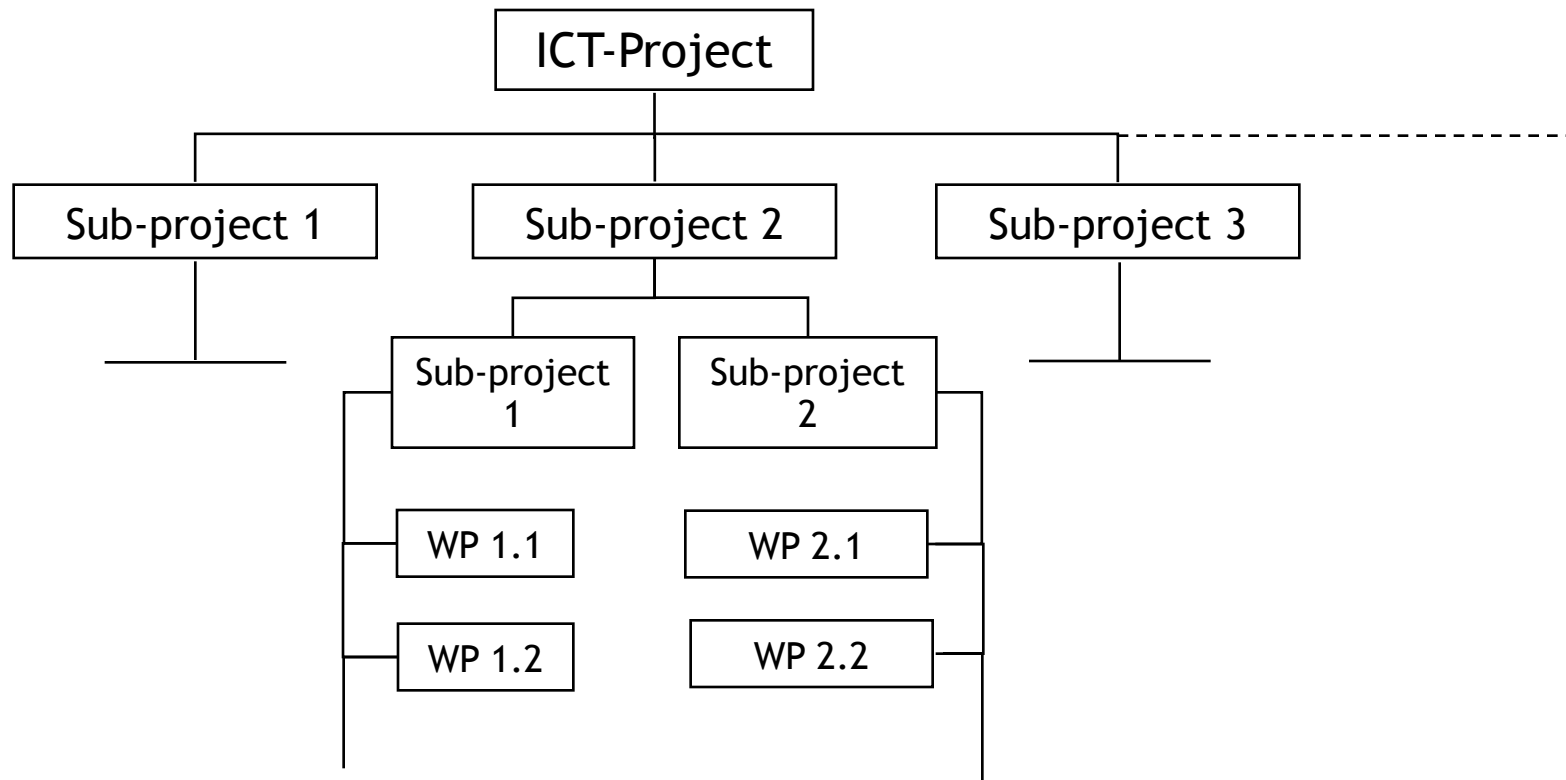

- Breakdown of the project in sub-projects and work packages (WP).
- If the resulting project structure plan contains the efforts and responsibilities, it is called a Work Breakdown Structure (WBS).

- Effort estimation denotes the process of identifying the overall effort for a project, its sub-projects and work packages. It is part of the planning and controlling tasks.
- The effort is typically measured in “man” or “person” days. One “man” or “person” day is the working capacity of an average employee required to accomplish a certain task in one day.
- ICT Projects are in general very different in terms of
 - Project objectives
 - Project duration
 - Complexity
 - Used technology
- Effort for ICT Projects can hardly be calculated, but has to be estimated.

- Productivity method
 - Calculation is based on finished projects.
 - E.g. estimation via "Lines of Code" of a software
- Analogy method
 - Comparison of finished projects based on defined criteria.
 - E.g. interfaces, number of modules, program structure, etc.
- Top-down method
 - Decomposition of the project in smaller parts, until a realistic estimation can be performed
- Bottom-up method
 - Projection of the total effort based on the effort for a representative part of the project

Development of an Individual Information System (Example):

- Hardware costs (direct / indirect)
- + Software costs (direct / indirect)
- + Material costs (direct / indirect)
- + Employee training costs
- + Project Personnel costs

Personnel costs are typically calculated by multiplying the **estimated person days/months** with the **cost rates** of the corresponding project participants.

+ ...

= Total project costs

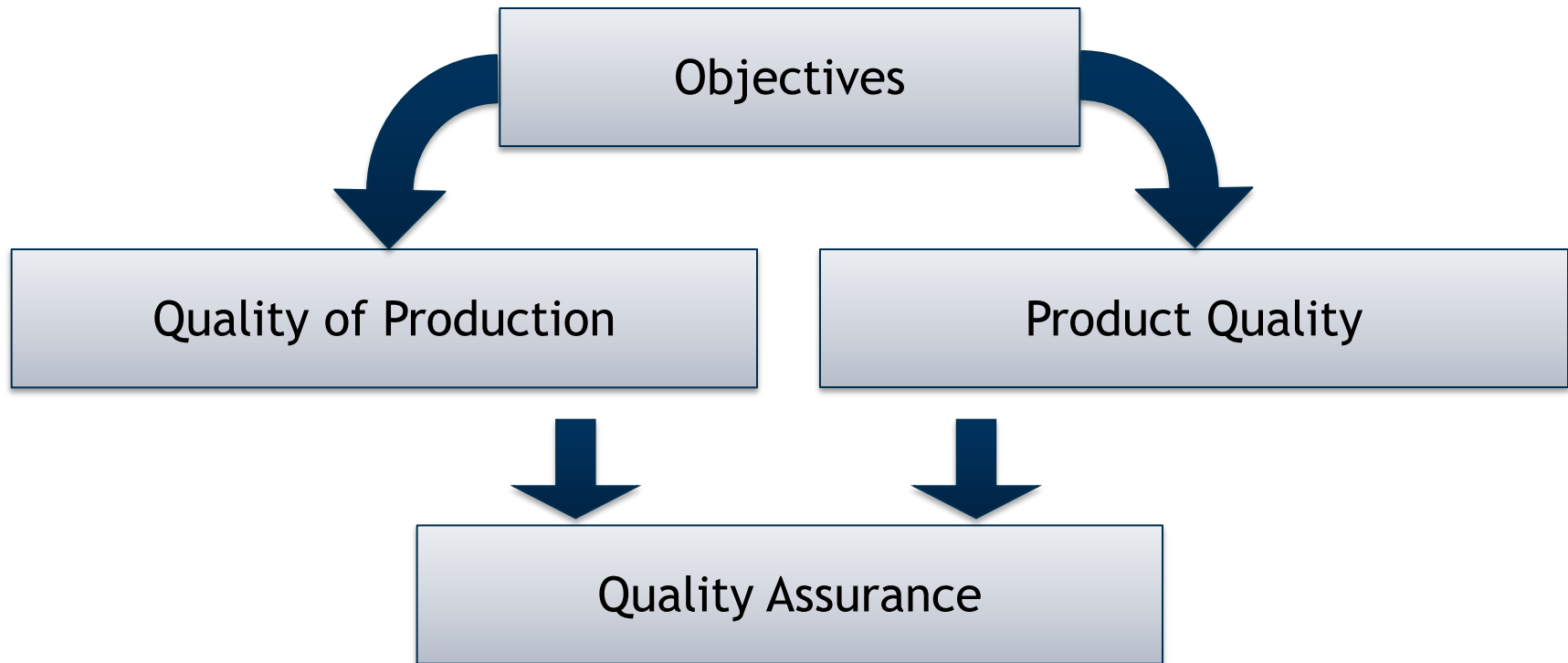

- Quality Management is intended to ensure that the project meets its intended objectives.
- Differentiation between product and production quality
 - Product quality
 - Requirements regarding the product itself
 - The software product meets the specified requirements.
 - Production quality
 - Requirements regarding the development process of the product
 - Software product is created on time, costs and requirements (i.e. the product quality) have been met.

- Example: ISO 9000 standards
 - Framework for designing the quality management
 - General requirements catalogue
- Often used to certify companies regarding their quality assurance:
 - It is certified that the company complies with the regulations of ISO 9000.
 - It is NOT certified how the regulations are implemented!

- **Functionality:** Specified functions are included in the software.
- **Robustness:** The software is stable and includes routines to handle runtime errors.
- **Usability:** The software is easy and intuitive to use.
- **Efficiency:** The software fulfils its purpose, using only necessary resources.
- **Scalability:** The software is easily adaptable, extendable to new requirements.
- **Portability:** The software can be transferred to another system platform with a reasonable effort.

- Danezis (2017): The politics of the NHS WannaCrypt ransomware outbreak,
<https://conspicuouschatter.wordpress.com/category/policy/>
- Goldstein, H. (2005): Who killed the Virtual Case File,
<http://spectrum.ieee.org/computing/software/who-killed-the-virtual-case-file>
- Heise (2022) https://www.heise.de/news/Steuerzahlerbund-ruegt-Luca-App-digitalen-Impfnachweis-und-IT-Chaos-beim-Bund-6262887.html#nav_luca_im_voraus__0
- Kargl H. (2000) "Management und Controlling von IV-Projekten", München, Wien, Oldenbourg.
- Laudon, K.C.; Laudon, J.P.; Schoder, D. (2006) "Wirtschaftsinformatik - Eine Einführung".
- Scott, J.E. (1999): The Fox-Meyer Drugs bankruptcy: was it a failure of ERP?, The 5th Americas Conference on Information Systems. Milwaukee, WI: AMCIS.
- Standish Group (2009): CHAOS Summary 2009,
http://www1.standishgroup.com/newsroom/chaos_2009.php



- Stellmann, A.; Greene, J. (2011): Applied Software Project Management, O'Reilly Media Inc 2006.
- Strahtmann (2017): <http://www.sueddeutsche.de/digital/it-panne-sechs-jahre-millionen-euro-aber-keine-software-fuer-die-arbeitsagentur-1.3382464>
- Taimur, A. N. (2005): Why IT Project Fail, The PROJECT PERFECT White Paper Collection
http://www.projectperfect.com.au/downloads/Info/info_it_projects_fail.pdf

